

i Lees a.u.b. aandachtig deze handleiding voordat je de weger in gebruik neemt

1. Digitaal display
2. Aan/uit knop
3. Modus schakelaar
4. SUM knop
5. Belastgebied
6. Oplaadindicator
7. Resetknop
8. TYPE-C oplaadpoort, Oplaadkabel meegeleverd

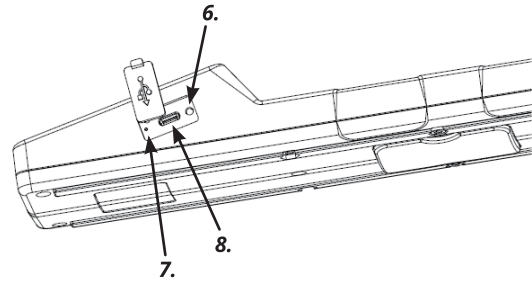
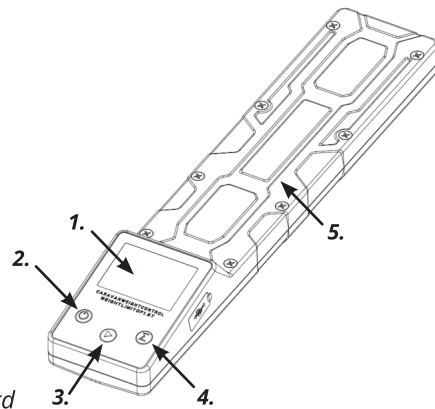

Aan/uit knop Druk  knop om aan te zetten en houd  3 seconden in om uit te schakelen.

Modus schakelaar:

1. Druk op aan/uit knop om te starten
2. Houd de SUM knop ingedrukt en druk op de Mode Switch knop om van modi te wisselen
3. Er is keuze uit drie modi, zie onderstaand

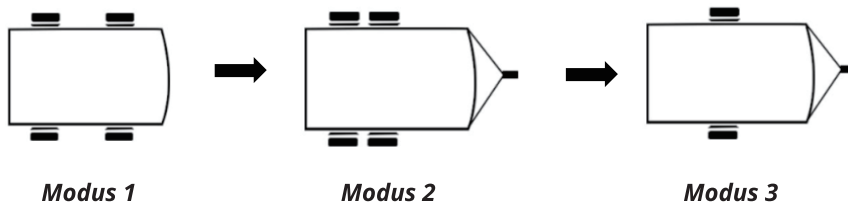

Resetknop:

Als het display uitvalt of de aan/uit functie uitvalt, steek dan de reset-tool in het 07-gat, druk de resetknop in en de weger zal terugkeren naar de oorspronkelijke 'staat'

Batterij indicator:

Wanneer de weger volledig is opgeladen, wordt het batterijpictogram niet meer weergegeven op het scherm. Wanneer het batterijpercentage minder dan 15% is, wordt het batterijpictogram weergegeven als volgt:

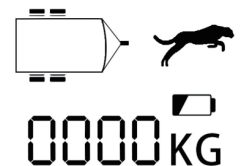

Specificaties:

Maat: 360 x 72 x 47 mm

Gewicht: 1,28 kg

Batterijspecificaties: 3,7 V, 600 mAh lithium-polymeerbatterij

Ingangsspanning/stroom: 5V / 0,6A

Accucapaciteit: 15 uur (circa 60 gebruikrondes)

Waterdichtheid: IP44

Waarschuwing:























1. Gebruik de weger niet bij gewichten boven de 1500 kg.
2. Het bedieningspaneel mag niet worden samengedrukt door zware voorwerpen.
3. Het product mag niet worden ondergedompeld in water of langdurig gebruikt/bewaard worden in een vochtige omgeving.
4. Bij het meten van het gewicht van het object is de nauwkeurigheidstolerantie 2,5%.
5. Zorg dat dit product gebruikt wordt op een vlakke en harde ondergrond.



CE IP44

 Lees a.u.b. aandachtig deze handleiding voordat je de weger in gebruik neemt



Definitie van de symbolen:

Programma 1	Programma 2	Programma 3
<p>Caravan en aanhanger met enkele as</p>   <p>Weeg neuswiel</p>  <p>Weeg rechter wiel</p>  <p>Weeg linker wiel</p>  <p>Totaalgewicht</p>	<p>Caravan en aanhanger met dubbele as</p>   <p>Weeg neuswiel</p>  <p>Weeg rechter wiel</p>  <p>Weeg linker wiel</p>  <p>Totaalgewicht</p>	<p>Camper en voertuig</p>   <p>Weeg rechter voorwiel</p>  <p>Weeg rechter achterwiel</p>  <p>Weeg linker voorwiel</p>  <p>Weeg linker achterwiel</p>  <p>Totaalgewicht rechterzijde van het voertuig</p>  <p>Totaalgewicht linkerzijde van het voertuig</p>  <p>Totaalgewicht voertuig</p>
		
 <p>Je hebt te snel over de weger gereden, weeg dit wiel opnieuw</p>		
 Symbool knippert  Symbool licht op		

 **Please read the manual carefully before using this product**

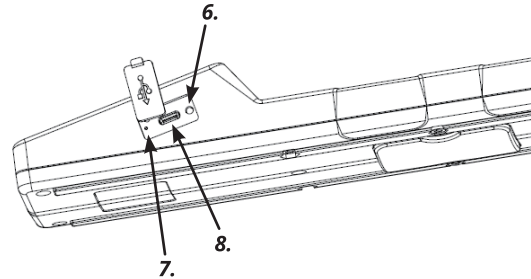
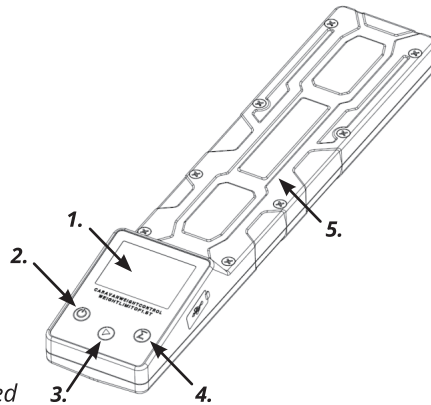
1. Digital display
2. On/off button
3. Mode switch button
4. SUM button
5. The area for load-bearing
6. Charging Indicator
7. Reset switch
8. TYPE-C charging port, Charging cable included



Power ON/OFF Press  to switch on and hold  for 3 seconds to switch off.

Mode switch:

1. Press on/off button to start
2. Hold the SUM button, then press the Mode Switch button to switch modes
3. There are three modes to choose from, illustrated below

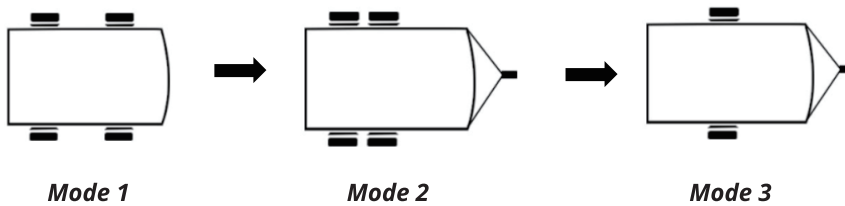

Reset switch:

When the display area of the product function fails or the power switch function fails, insert the reset-tool into the 07 hole, start the reset switch, the product will return to the initial 'state'

Battery indicator:

When product is fully charged, the screen doesn't show the battery icon.
When the power is less than 15%, the battery icon displays as the following figure:

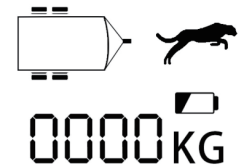

Specifications:

- Size: 360 x 72 x 47 mm
- Weight: 1,28 kg
- Battery Specification: 3,7 V, 600mAh Lithium polymer battery
- Input voltage/current: 5V / 0,6A
- Battery capacity: 15 hours (approximately 60 rounds of use)
- Waterproof grade: IP44

Warning:























1. Don't measure the weight of product over 1500 KG.
2. The control panel must not be compressed by heavy objects.
3. The product should not be immersed in water or be used/stored for long periods of time in a humid environment.
4. When measuring the weight of the object, the accuracy tolerance is 2.5%.
5. Please make sure to use this product on a hard and even surface



CE IP44

Please read the manual carefully before using this product



Definition of symbols:

Programme 1	Programme 2	Programme 3
<p>Caravan single axle and trailer</p>	<p>Caravan twin axle and trailer</p>	<p>Motorhome and vehicle</p>
		
		
<p>Weight jockey wheel</p>	<p>Weight jockey wheel</p>	<p>Weight right front wheel</p>
		
<p>Weight right wheel</p>	<p>Weight right wheel</p>	<p>Weight right back wheel</p>
		
<p>Weight left wheel</p>	<p>Weight left wheel</p>	<p>Weight left front wheel</p>
		
<p>Total weight</p>	<p>Total weight</p>	<p>Weight left back wheel</p>
		
 <p>You have driven too fast over this Weight Control. Reweigh this wheel</p>		<p>Total weight of left side of vehicle</p>
		
		<p>Total weight of right side of vehicle</p>
		
		<p>Total weight of the vehicle</p>
<p> Symbol is blinking</p>		<p> Symbol is lighting up</p>

 **Bitte lesen Sie diese Betriebsanleitung sorgfältig durch, bevor Sie die Waage in Betrieb nehmen**

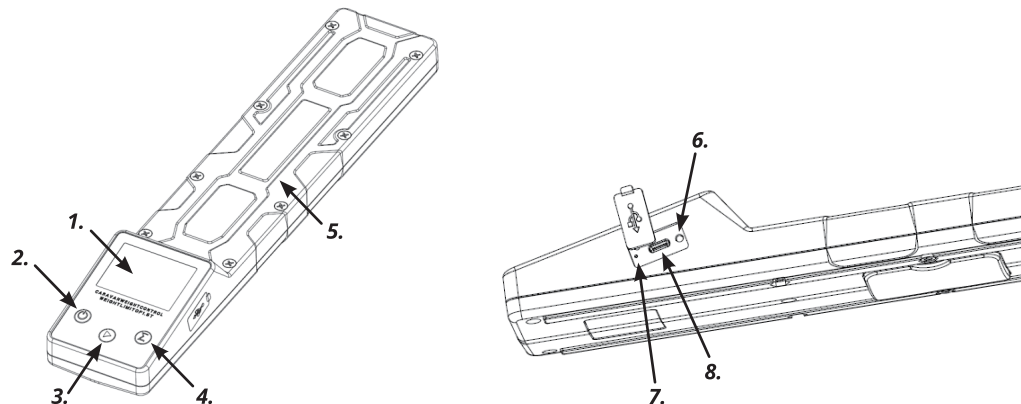
1. Digitales Display
2. Ein/Aus-Taste
3. Modustaste
4. SUM-Taste
5. Lastbereich
6. Batterieanzeige
7. Resettaste
8. TYP-C Ladeanschluss, Ladekabel enthalten



Ein-/Ausschalten Zum Einschalten  drücken und zum Ausschalten  3 Sekunden lang gedrückt halten.

Modustaste:

1. Zum Starten Ein/Aus-Taste drücken
2. Halten Sie die SUM-Taste gedrückt und drücken Sie dann die Mode Switch-Taste, um den Modus zu wechseln
3. Es stehen drei Modi zur Auswahl, die unten abgebildet sind

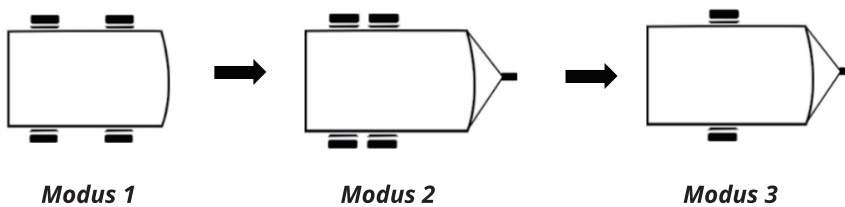

Resettaste:

Wenn das Display oder die Ein/Aus-Funktion ausfällt, bitte die Reset-Spitze in das 07-Loch stecken und die Resettaste drücken. Dann wird die Waage wieder in ihren ursprünglichen 'Zustand' zurückkehren

Batterieanzeige:

Sobald die Waage vollständig aufgeladen ist, wird das Batteriesymbol nicht mehr im Display angezeigt. Bei einer Restkapazität von höchstens 15% wird das Batteriesymbol wie folgt angezeigt:

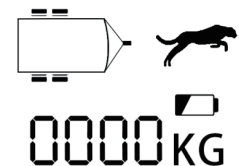

Spezifikationen:

Größe: 360 x 72 x 47 mm
 Gewicht: 1,28 kg
 Batteriespezifikationen: 3,7 V, 600mAh Lithium-Polymer-Batterie
 Eingangsspannung/Strom: 5V / 0,6A
 Akkukapazität: 15 Stunden (ca. 60 Einsatzrunden)
 Wasserdichtigkeit: IP44

Warnung:























1. Waage nicht für Gewichte über 1500 kg verwenden.
2. Das Bedienungsdisplay sollte nicht durch schwere Gegenstände zusammengedrückt werden.
3. Das Produkt sollte nicht in Wasser eingetaucht oder über einen längeren Zeitraum in einer feuchten Umgebung verwendet/gelagert werden.
4. Beim Wiegen des Objektes beträgt die Genauigkeitstoleranz 2,5%
5. Stellen Sie sicher, dass dieses Produkt auf einer ebenen und harten Oberfläche verwendet wird.



CE IP44

 **Bitte lesen Sie diese Betriebsanleitung sorgfältig durch, bevor Sie die Waage in Betrieb nehmen**

Bedeutung der Symbole:

Programm 1	Programm 2	Programm 3
Wohnwagen / Anhänger mit Einzelachse	Wohnwagen / Anhänger mit Doppelachse	Wohnmobile und sonstige Fahrzeuge
		
		
Stützrad	Stützrad	Linkes Vorderrad wiegen
		
Linkes Rad wiegen	Linkes Rad wiegen	Linkes Hinterrad wiegen
		
Rechtes Rad wiegen	Rechtes Rad wiegen	Rechtes Vorderrad wiegen
		
Gesammtgewicht	Gesammtgewicht	Rechtes Hinterrad wiegen
		
		Gesammtgewicht linke Fahrzeugseite
 <p>Sie sind zu schnell über die Waage gefahren, dieses Rad bitte noch einmal wiegen</p>		
		Gesammtgewicht rechte Fahrzeugseite
		
		Gesammtgewicht des Fahrzeugs
 Symbol blinkt		 Symbol leuchtet